

READ AND SAVE THESE INSTRUCTIONS

EN

ThinAir® HAND DRYER



MODELS: TA - **ABS** **GR** **SB** **SI** **SP** **W** WITH OR WITHOUT SUFFIX **V** **K** AND/OR **H**

INSTALLATION AND OWNER'S MANUAL

CONTENTS OF BOX

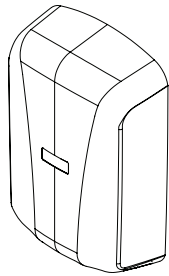

1 Hand Dryer



2 Tamper-Proof Wrench
Knockout Gasket (included
for use with Model TA-ABS only)



3 Installation and Owner's Manual

MODEL INFO

Dryer Model

Serial Number

Date Of Purchase



WARNING: TO REDUCE THE RISK OF FIRE, ELECTRIC SHOCK OR INJURY TO PERSONS, OBSERVE THE FOLLOWING:

- A. Use this unit only in the manner intended by the manufacturer.
- B. Before servicing or cleaning unit, switch power off at service panel and lock the service disconnecting means to prevent power from being switched on accidentally. When the service disconnecting means cannot be locked, securely fasten a prominent warning device, such as a tag, to the service panel.
- C. For proper electrical connections, check your local building codes. Your unit must be installed by a qualified, licensed electrician.

PRE-INSTALLATION WIRING

- Check that the electrical supply corresponds to that shown on the rating sticker of unit. If the dryer is connected to any electrical supply other than that stated on the rating sticker of the unit, permanent damage or improper, unsafe operation of the unit may result.
- Make sure electricity is switched off at the main panel before installing, maintaining or cleaning this hand dryer. Dryer must be installed in accordance with current local wiring and building regulations.
- Dryer is intended to be permanently connected to power supply, and must be properly grounded.

SAFETY

- Troubleshooting and internal maintenance must be performed by qualified service personnel.
- Do not use any power wash equipment for cleaning on or near this unit.
- Do not use for drying hair.
- Do not obstruct air inlets or outlets.



EXCEL DRYER, INC 1.413.525.4531 1.800.255.9235 (US/CN) EXCELDRYER.COM
ADMIN@EXCELDRYER.COM 357 CHESTNUT STREET, EAST LONGMEADOW, MA 01028

2/2021

1

READ AND SAVE THESE INSTRUCTIONS

INSTALLATION INSTRUCTIONS

1. Disconnect the power source previously brought to the hand dryer location (see pre-installation wiring above).
 2. Use the Tamper-Proof Wrench supplied and remove the Tamper-Proof Bolt on bottom of cover lifting upwards to remove cover from base plate.
 3. If electrical wiring entry is to be made from the rear, remove the appropriate pre-formed knockout on the base plate. If entry is to be made from the side, knock out the preformed area on the right side of cover for your supply connection using knockout gasket provided. A rigid conduit must be used. **For models with metal covers**, if the side entry for conduit is required, this must be specified in advance and the side entry can be pre-cut and proper grommet applied by the manufacturer.
 4. Select the appropriate mounting height for dryer (Table 1) and fastener, as recommended (Table 2). There should be no obstruction between the hand dryer and the floor. If mounting over a countertop, distance from counter to dryer must be 15" (381 mm) minimum.
- CAUTION:** Do not use Base Plate as a guide when drilling. Make sure no pipe work (gas, water, air) or any electrical cables or wires are located directly behind the area to be drilled.
5. Attach Base Plate at the four corners to smooth wall. Use one of 2 knockouts provided for service entry on back of Base Plate. If using surface wiring use knock out in right side of cover. Use Knockout Gasket supplied around conduit for water seal. See Mounting Details.
 6. Identify the voltage of your dryer from the rating sticker of the unit. Then connect to a circuit per your local wiring and building regulations.
 7. Secure electrical wiring to terminals as indicated by the schematic affixed to blower housing. An identified ground connection point is supplied on the Base Plate for your equipment ground wire. Dryers should be installed per local code requirements.
 8. In multiple installations, make sure the serial number marked on the inside matches the cover number. Then carefully replace Cover by inserting top of cover over bracket and tilting downward. Use Tamper-Proof Bolt previously removed in step 2.
 9. Restore power and test for proper operation.
 10. Return Tamper-Proof Wrench to owner.

MOUNTING DETAILS

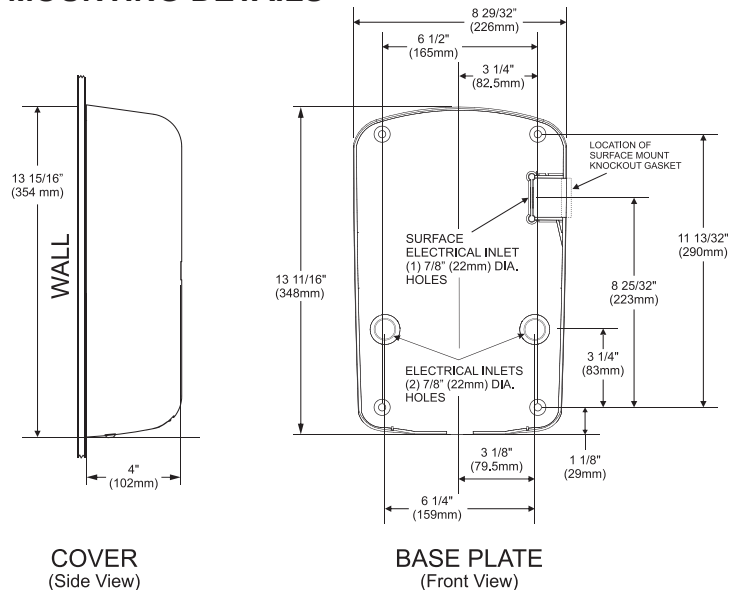

CLEANING / MAINTENANCE

Disconnect power to the dryer before cleaning. It is recommended that you refer to the WHO or CDC for handling guidelines when cleaning the Pre-Filter or replacing the HEPA filter if either may have been exposed to a contagion.

- OUTSIDE:** Gently wash Cover (including air inlet holes) using a soft cloth or sponge and a mild soap or detergent with lukewarm water to loosen dirt and grime.
- INSIDE:** It is recommended to inspect the inside of the dryer and clean at least twice per year. Excessive lint, dust or other particles in the air may require more frequent cleaning. Lint on the air inlet, the dryer Pre-Filter, HEPA filter (if so equipped) or other internal parts of dryer will reduce efficiency and shorten the life of the working parts.
- TO CLEAN:** Use the Tamper-Proof Wrench supplied and remove the Tamper-Proof Bolt on bottom of cover, lifting upwards to remove cover from base plate. Gently clean all parts using a small soft brush. Remove the PreFilter, rinse with water and dry. Inspect the HEPA Filter (if so equipped) for any excessive debris buildup whenever the Pre-Filter is removed. **DO NOT CLEAN THE HEPA FILTER OR ALLOW IT TO COME INTO CONTACT WITH WATER.** Reinstall the Pre-Filter, cover and restore power.

TABLE 1

1 SUGGESTED MOUNTING HEIGHT from floor to bottom of dryer:

Men	45" (114 cm)
Women	43" (109 cm)
Teenagers	41" (104 cm)
Small Children	35" (89 cm)
Accessible	37" (94 cm)

TABLE 2

2 MOUNTING HARDWARE Recommended Fastener (not supplied):

Masonry Wall	1/2" Expansion Sleeve with 1/4" Lag Bolt
Hollow Wall	1/4" Wing Type Toggle Bolt
Wooden Wall	1/4" Lag Screw With Washer

PLEASE SEE OUR WEBSITE, www.exceldryer.com FOR WARRANTY, TROUBLESHOOTING, AND PARTS INFORMATION



EXCEL DRYER, INC 1.413.525.4531 1.800.255.9235 (US/CN) EXCELDRYER.COM
 ADMIN@EXCELDRYER.COM 357 CHESTNUT STREET, EAST LONGMEADOW, MA 01028

2/2021

2

READ AND SAVE THESE INSTRUCTIONS

TROUBLESHOOTING

Dryer does not turn on

1. Check power to the unit and connections. Verify dryer is receiving correct voltage at Terminal Block (check Dryer listed voltage).
2. Check RED service LED light for the following:
Light is ON – Place hands under Sensor for 10 sec. If light stays on, check Sensor connection at control. If OK, replace Sensor or Control. If light goes off and then flashes a code, see error codes in CODE chart. If light still stays on, replace Control.

Light is OFF – Check for loose, disconnected or improper wiring (See wiring schematic inside dryer Cover), or replace Control Assembly.

Light is FLASHING – See error codes in CODE chart.

SENSOR RANGE ADJUSTMENT: *If dryer will not turn on, stays on, or stops working, it may be mounted too close to a counter or object and has gone into lockout. If relocating appliance is not possible, adjust the range of the Sensor. Turn off power to dryer then turn the range adjustment on the Control Assembly counterclockwise towards L (-) low to decrease Sensor range.*

Dryer does not shut off

1. May be mounted too close to a counter or object (adjust Sensor range).
2. Check for loose, disconnected or improper wiring (Refer to wiring schematic affixed to blower housing).
3. Replace Control Assembly.

Dryer does not always turn on or turns on by itself

1. May be mounted too close to counter or object (adjust Sensor range).
2. Check for foreign material on Optical Sensor next to Air Outlet.
3. Check for loose wires on Control Assembly.
4. Replace Control Assembly.

Dryer heats up but no air comes out

1. Check wire connections to Motor.
2. Replace Motor.

Dryer blows only cold air

1. Check heat setting on control.
2. Check for loose connections to Heating Element.
3. Replace Heating Element.

Dryer has a loss of air volume

1. Check motor speed setting on control.
2. Check for blockage at nozzle air outlet.
3. Check Dryer Pre-Filter for lint buildup. Check HEPA pre-filter (if so equipped). Clean by removing Pre-Filter and rinse in warm water then dry before reinstalling. A clogged filter code may be present in the sensor.
4. After cleaning Pre-Filter, check HEPA Filter (if so equipped). If dirty, replace HEPA Filter. **DO NOT RINSE HEPA FILTER.**

ADJUSTING THE HEAT OUTPUT, MOTOR SPEED AND SENSOR RANGE

The dryer is shipped with maximum heat and maximum motor speed. To adjust, turn the corresponding knob COUNTERCLOCKWISE to reduce.

H = Heat M = Motor R = Range

CODE CHART

Codes are displayed by flashing the red LED in the sensor behind air outlet. Normal operation will be indicated by the red LED being on when not drying and off when hands are under the sensor.

Dryer Maintenance Codes

1 Short / 1 Long flash	Clogged Pre-Filter, or if equipped clogged HEPA Filter	Remove and clean Pre-Filter or if clean, replace HEPA filter	Dryer will still run
1 Short / 2 Long flashes	Severely Clogged Filter, or if equipped clogged HEPA Filter	Remove and clean Pre-Filter or if clean, replace HEPA filter	Dryer will stop
2 Short / 1 Long flash	In lockout mode	Remove obstruction or adjust sensor range	Dryer stops until obstruction cleared or sensor range is adjusted

Motor Problem Codes

1 Long / 3 Short flashes	Motor over current	Measure voltage across the terminal block. If OK, replace motor	Dryer will stop
1 Long / 4 Short flashes	Motor under current	Measure voltage across the terminal block. If OK, replace motor	Dryer will stop

Heater Problem Codes

2 Long / 3 Short flashes	Shorted or incorrect heater	Replace heating element	Dryer will stop
--------------------------	-----------------------------	-------------------------	-----------------

If problem cannot be resolved with the above, please call the manufacturer at 1-800-255-9235 and one of our trained technicians will be happy to assist you.



READ AND SAVE THESE INSTRUCTIONS

PARTS LIST

Ref. No.	Description
TA-1	Cover (includes nameplate)
TA-2	Tamper-Proof Bolt
TA-3	Tamper-Proof Wrench
TA-4	Knockout Gasket
TA-5	Bracket Cover Hook
TA-6	Nozzle
TA-7	Optic Bracket
TA-8	Optic Assembly
TA-9	Finger Guard
TA-10	Heating Element Assembly
TA-11	Muffler Housing (output)
TA-12	Muffler Foam (output)
TA-13	Motor Gasket Ring
TA-14	Clamshell Upper
TA-15	Bracket Cover
TA-16	Control Assembly
TA-17	Motor
TA-18	Motor Gasket
TA-19	Pre-Filter W/Screen
TA-20	Muffler Foam (input)
TA-21	Muffler Housing (input)
TA-22	Clamshell (lower)
TA-23	Base Plate
TA-24	Nameplate
TA-25	Tube (pressure)
TA-26	Terminal Block
TA-29	HEPA Pre-Filter W/Screen
TA-30	HEPA Filter

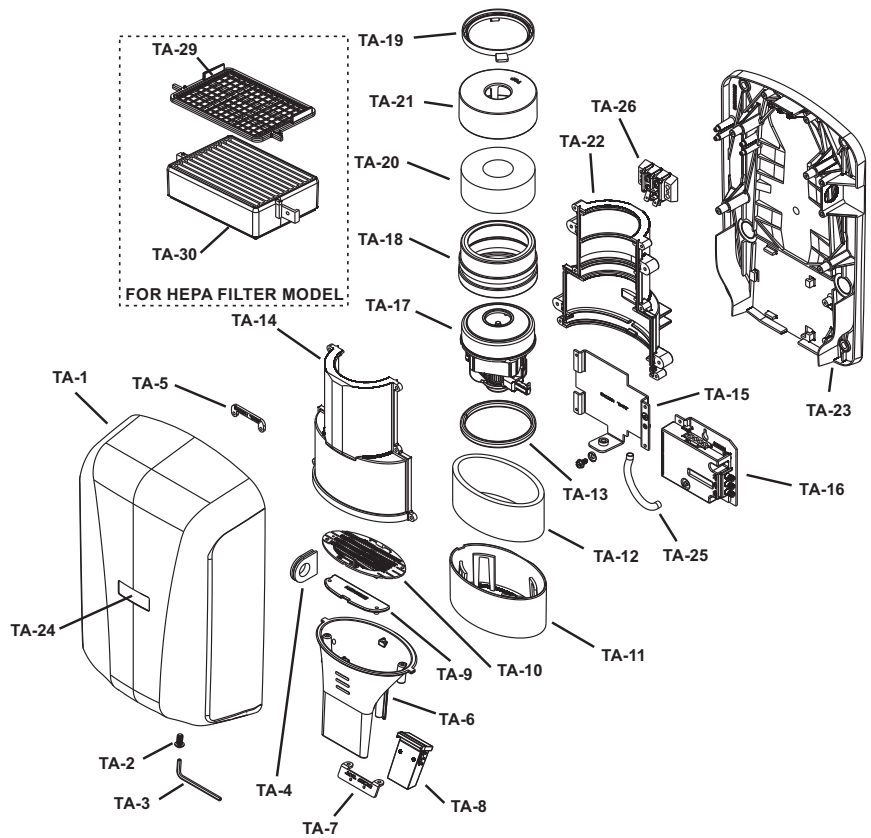

5-YEAR LIMITED WARRANTY (U.S. Only)

1. This product is warranted to be free of manufacturing defects for five (5) years (one [1] year on HEPA Filter & Pre-Filter) from the date of shipment from the Manufacturer's factory at 357 Chestnut St., East Longmeadow, Massachusetts 01028. This warranty explicitly excludes normal wear and tear on the Filter or Pre-Filter, as well as faulty installation, accident, misuse or vandalism.

In the event of a breach of the warranty described above, the Owner shall have either one of the following remedies:

- a. The Owner shall return the defective product to the Manufacturer, postage prepaid, and the Manufacturer shall repair said product within a reasonable time and free of charge, provided that said product is returned within the stated period above from the date of original shipment from the Manufacturer's factory in East Longmeadow, Massachusetts; and, provided further that said defect is not due to faulty installation, accident, misuse, or vandalism; **or**
 - b. The Owner may notify the Manufacturer by telephone or in writing of the defect and, within a reasonable time, the Manufacturer shall send a suitable replacement part to remedy said defect, and Owner shall be charged for said part at the current price level. The Owner may return the defective part to the Manufacturer, postage prepaid, along with the serial number of the defective product and the Manufacturer will then issue to the Owner a full credit for the repair part, including outgoing postage (within the Continental U.S. only). Said remedy is available only within the stated period stated above from the date of original shipment of the product from the Manufacturer's factory in East Longmeadow, Massachusetts; and provided further that said defect is not due to faulty installation, accident, misuse, or vandalism.
2. Any implied warranties of merchantability or fitness for a particular purpose are hereby limited to the duration of the express written warranty contained in paragraph one (1); namely, five (5) years (one [1] year on HEPA Filter & Pre-Filter) from the date of shipment from the Manufacturer's factory in East Longmeadow, Massachusetts.
 3. If you reside outside of the U.S., please contact the distributor you purchased the ThinAir from for warranty support.
 4. There are no other warranties and remedies except as contained herein. This warranty shall inure to the benefit of the Owners, Successors and Assigns.



TIME TO THROW IN THE TOWEL®

EXCEL DRYER INC • 1.413.525.4531 • 1.800.255.9235 (US/CN) • EXCELDRYER.COM

FEB
2021

19TAM0460